

Translations

1. Translate the figure 5 units right and 3 units up. List the coordinates of the image.

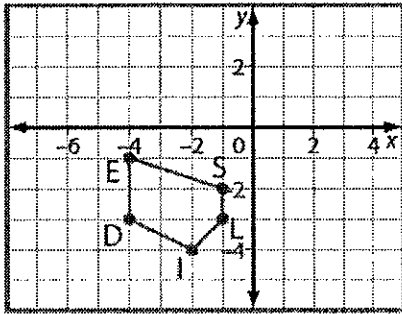

2. Describe the translation shown in the diagram.

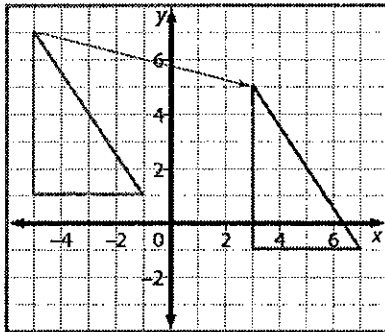

3. Point A is at (4, 2) on a coordinate grid. What are the coordinates of Point A after it is translated
- 3 units right?
 - 5 units down?
 - 6 units left and 1 unit up?
 - 2 units right and 8 units up?
 - 10 units left and 12 units down?

4. The plans for a new park are drawn on a coordinate grid. The climbing structure is placed at coordinates $M(-4, 4)$, $N(-3, 5)$, $R(-2, 4)$, $P(-2, 2)$, and $Q(-4, 2)$. The park manager wants to move the structure to Quadrant IV. She wants points M and Q to lie on the y -axis of the grid, and point N to lie on the x -axis.

- Plot MNRPQ on a coordinate grid.
- Draw MNRPQ in its new position.
- Describe the translation.

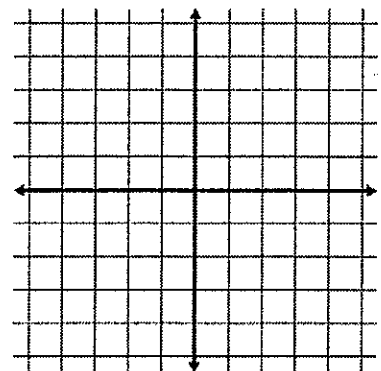

Reflections

1. Perform the following reflections.
 - a) Reflect Triangle ABC over the y-axis. Label the vertices A' , B' , and C' .
 - b) Reflect triangle ABC over the x-axis. Label the vertices A'' , B'' , and C'' .

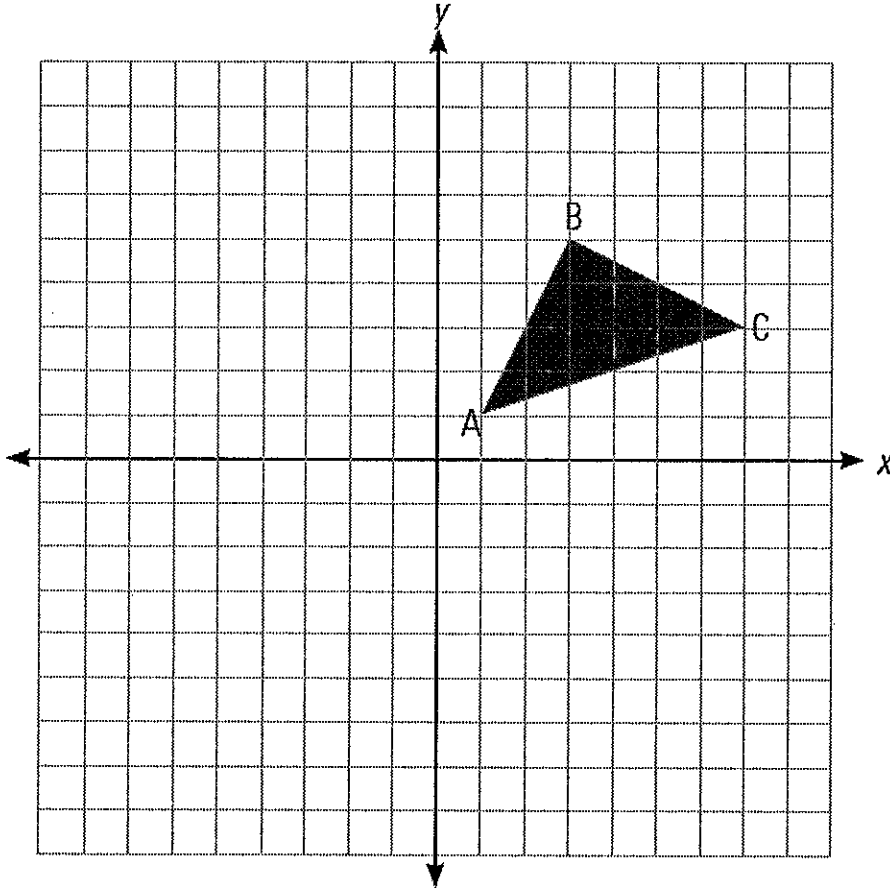

2. Draw the indicated line of reflection and then reflect the figure over the line of reflection.

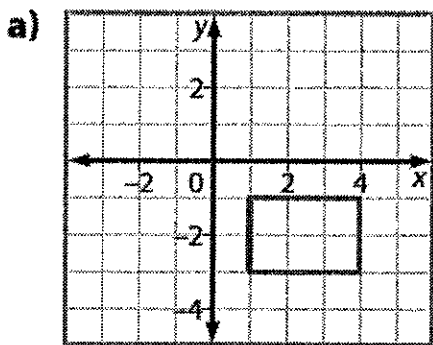

Line of reflection at $y = 1$

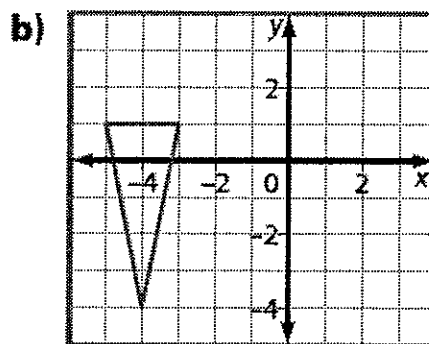

Line of reflection at $x = -2$

Completing reflections using equations of horizontal and vertical lines(E) positive quadrant

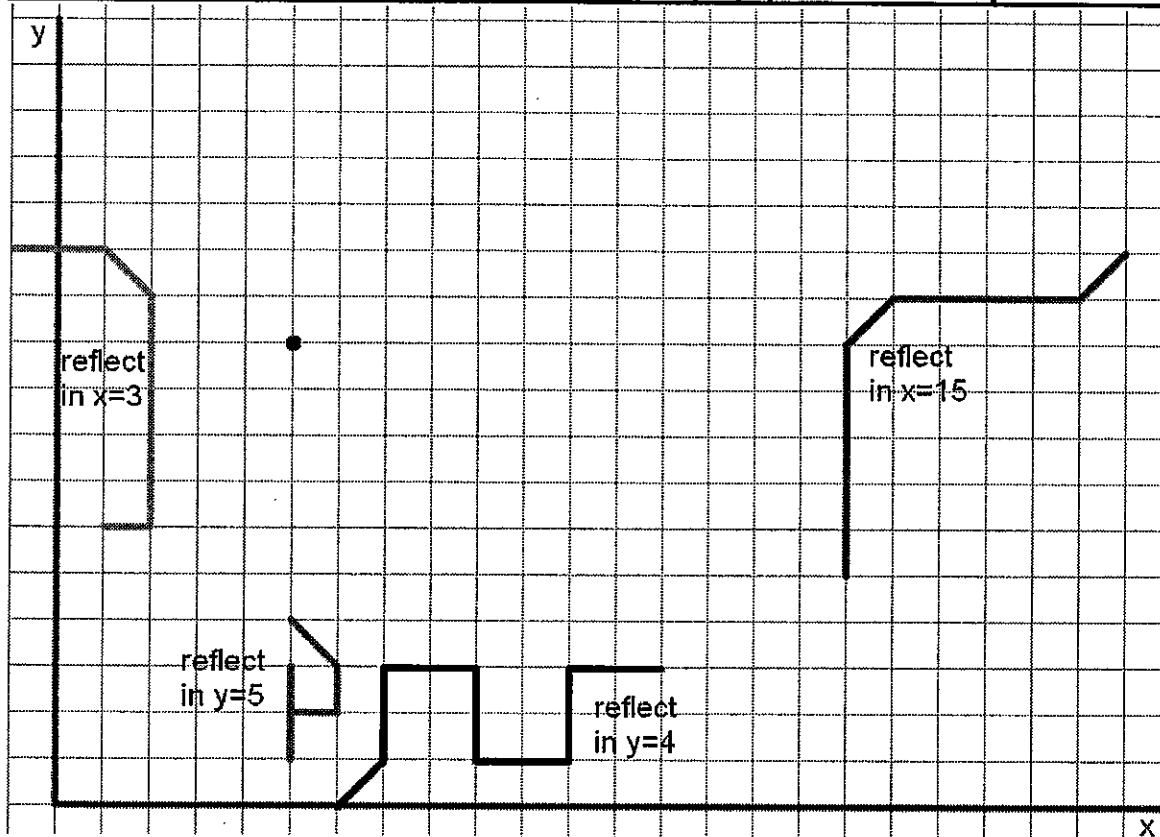

Completing reflections using equations of horizontal and vertical lines(E) all quadrants

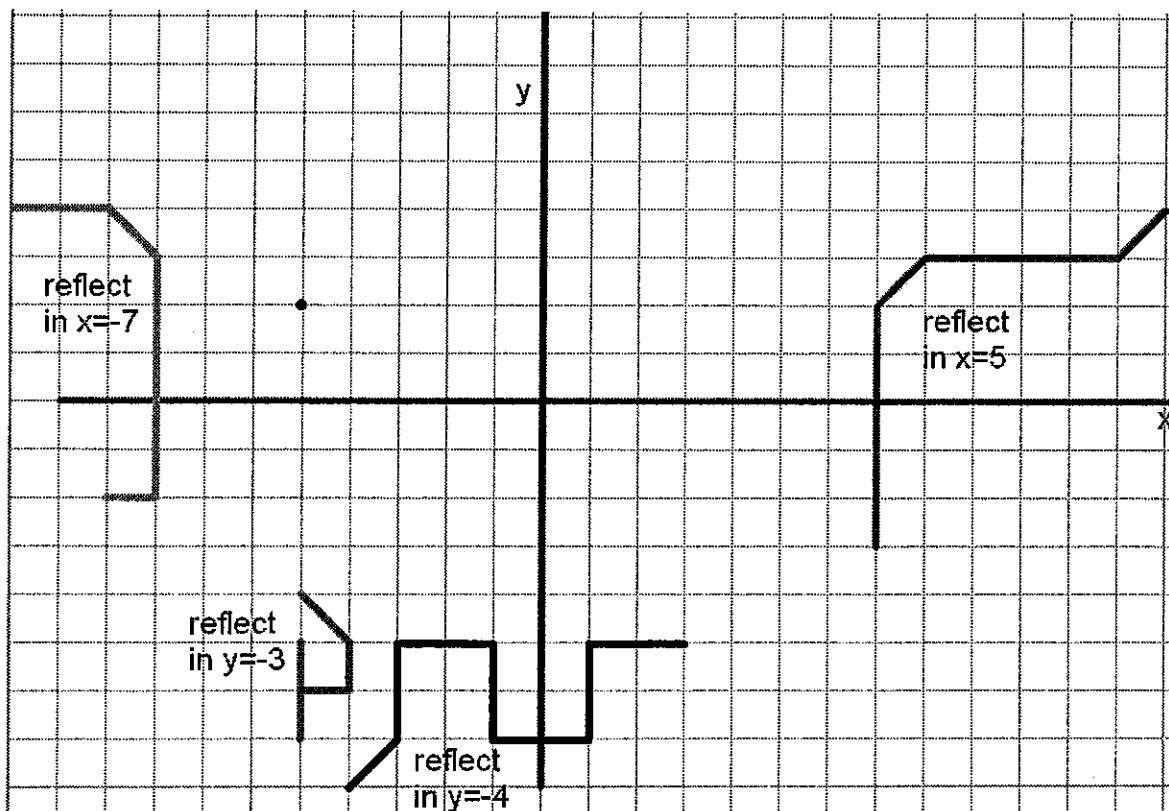

Using Equations of Horizontal and Vertical Lines (E)

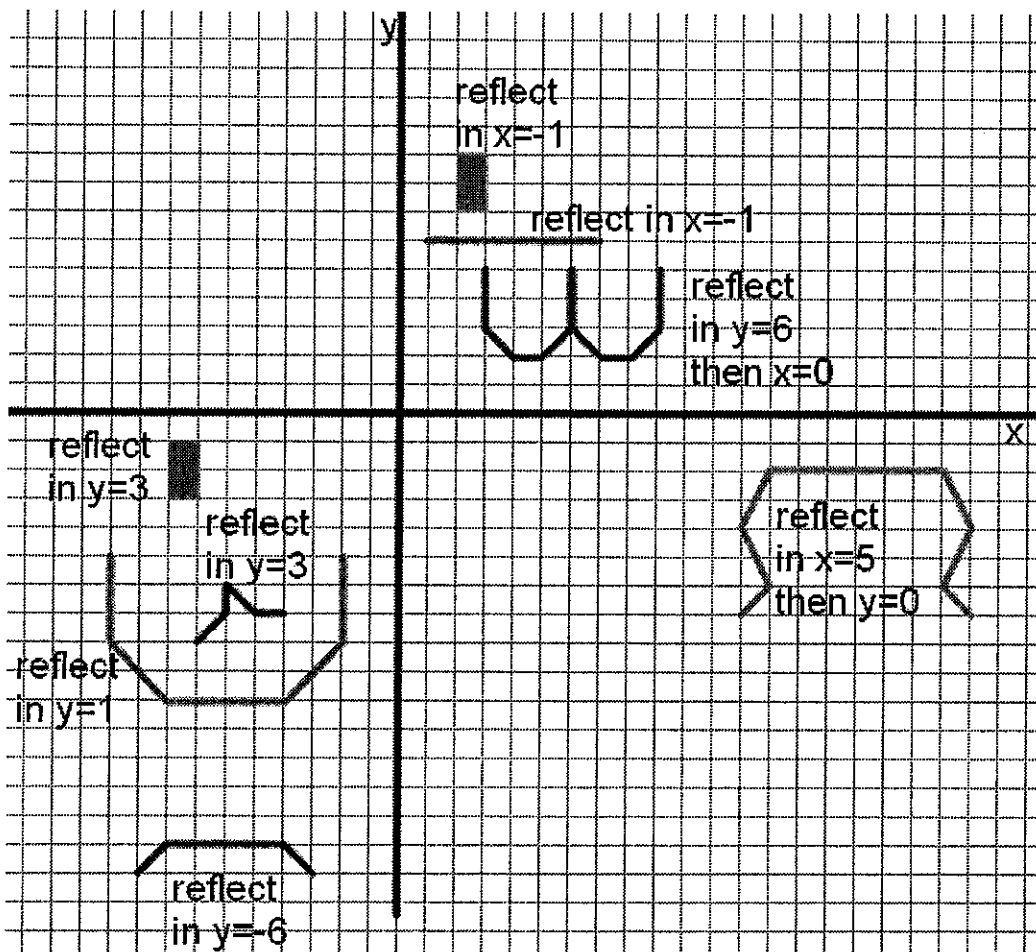
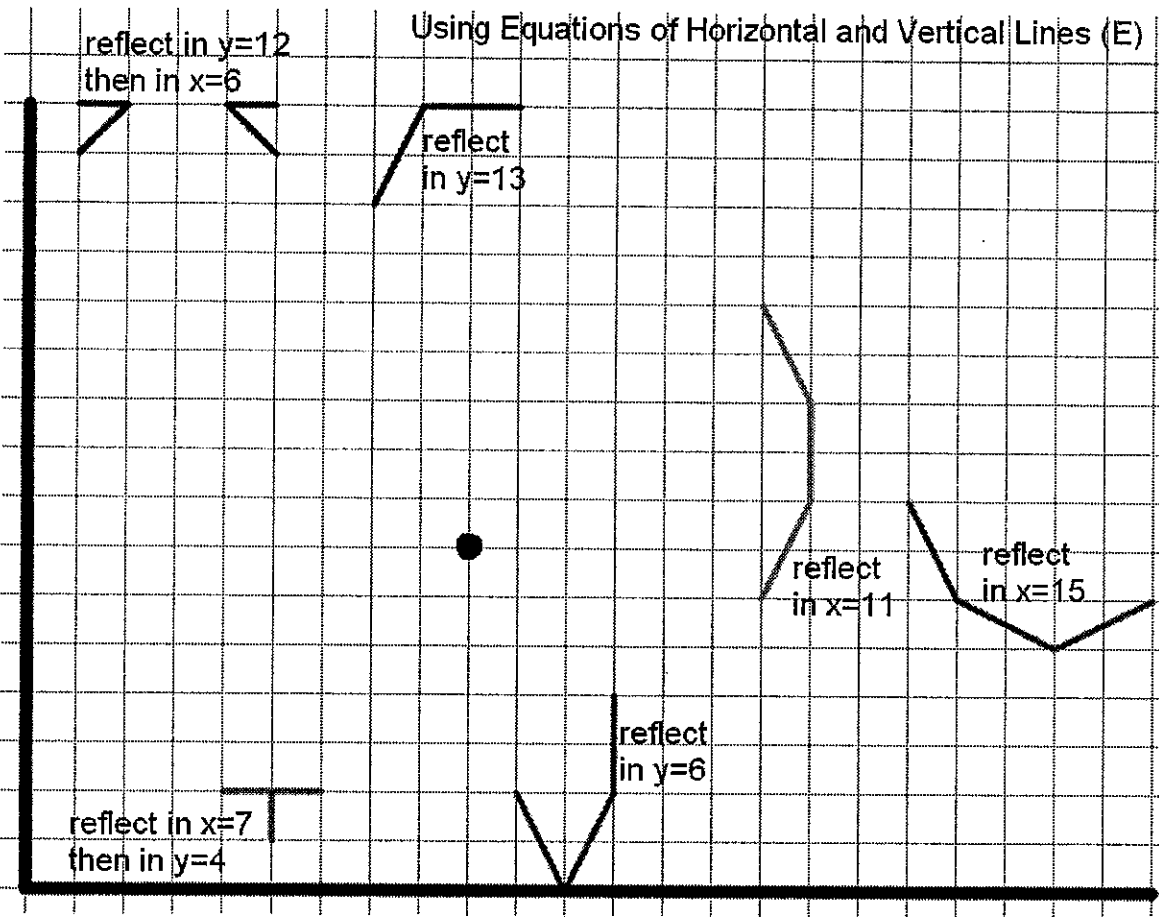

Rotations

1. Rotate triangle ABC about the origin:

a) 90° clockwise

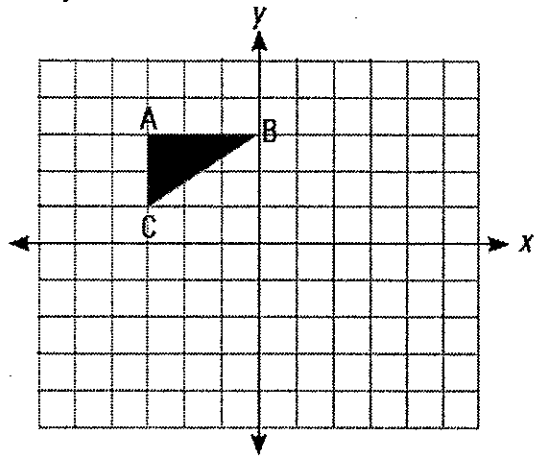

b) 180° counter clockwise

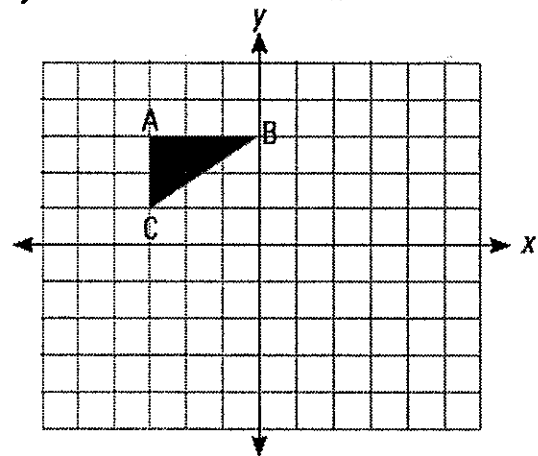

2. Perform the following rotations.

a) Rotate triangle ABC 90° counter clockwise about the origin.

Label the vertices A' , B' , and C' .

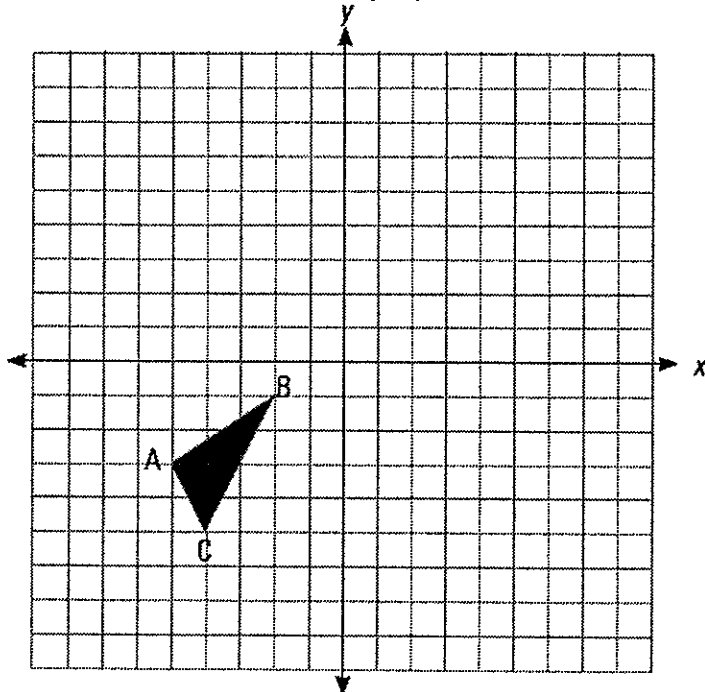

b) Now rotate triangle ABC 270° clockwise about the origin.

How does the resulting image compare to $A'B'C'$?

3. Misha is designing the propeller for a toy helicopter. The blades need to be evenly spaced around the origin (that is, three of the blades must be 90° , 180° , and 270° rotations of the first blade). Misha has drawn the following sketch of the propeller. If blade 1 is correctly placed, which of the other three blades is incorrectly drawn?

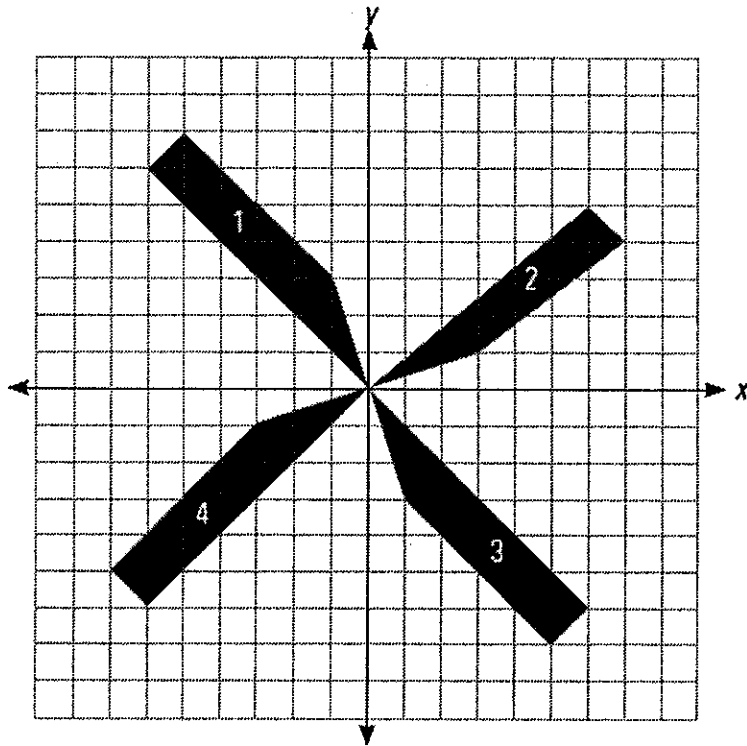

BUILD YOUR SKILLS

1. Rotate the following shape 270° clockwise about the origin, then translate it 2 units right and 3 units down. Show the intermediate step.

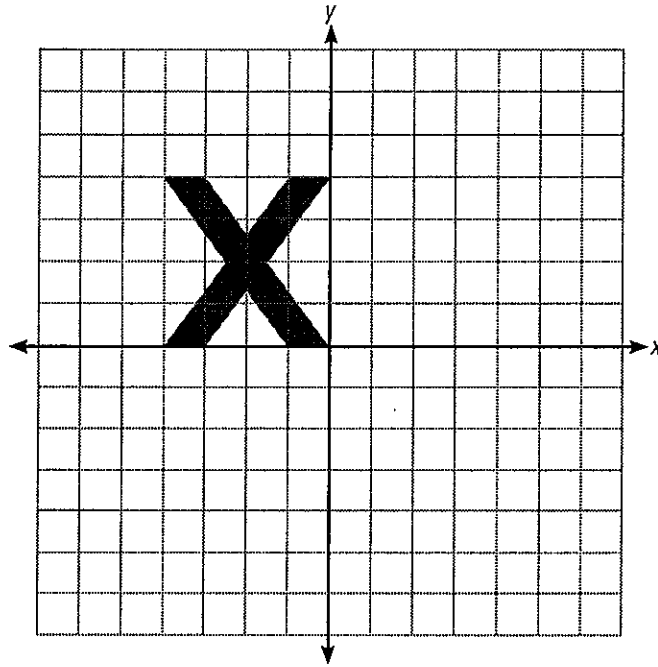

2. Shape 1 was rotated 180° clockwise about the origin, then translated to the position of shape 2. How far and in which direction(s) was the rotated image translated?

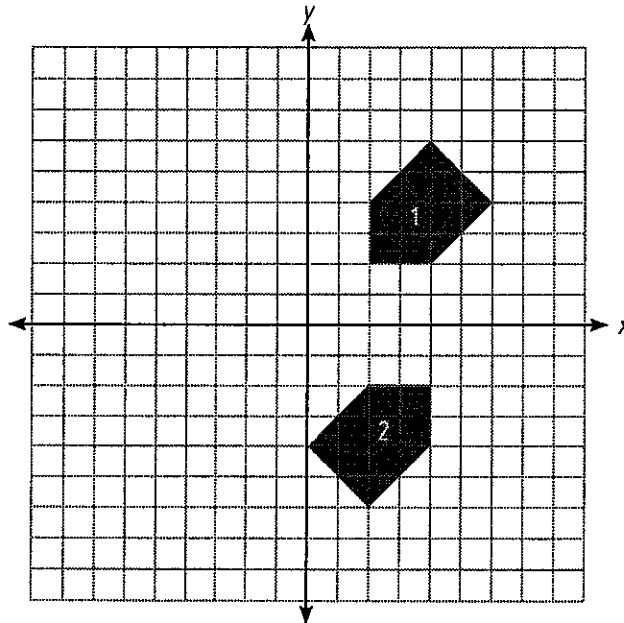

3. a) Rotate the following shape 90° clockwise about the origin, then translate it 6 units to the right.

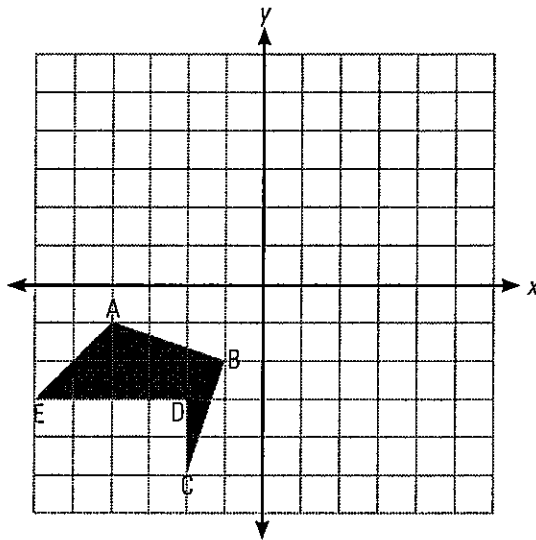

- b) Translate the shape 6 units right, then rotate it 90° clockwise about the origin.

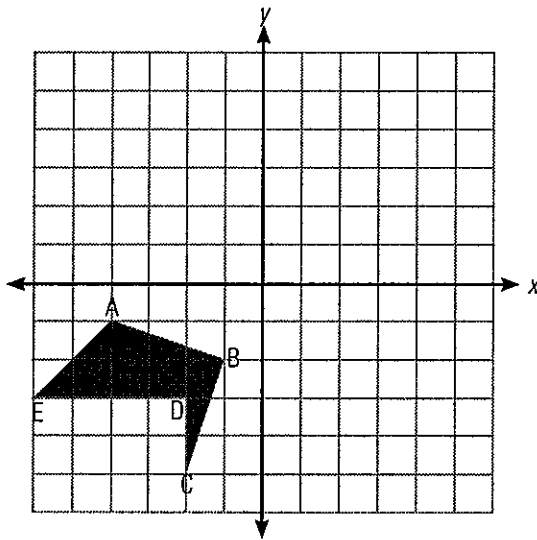

- c) Are the final images in a) and b) the same? Why or why not?

BUILD YOUR SKILLS

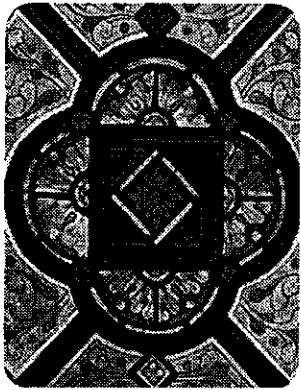

Stained glass was a popular art form in the Middle Ages, and was revived in the 19th century in Europe. Stained glass windows often incorporate patterns made of transformations. How many transformations can you identify in this design?

6. A single transformation (translation, reflection, or rotation) was used to move PQRS to P'Q'R'S'. Explain what transformation could have taken place.

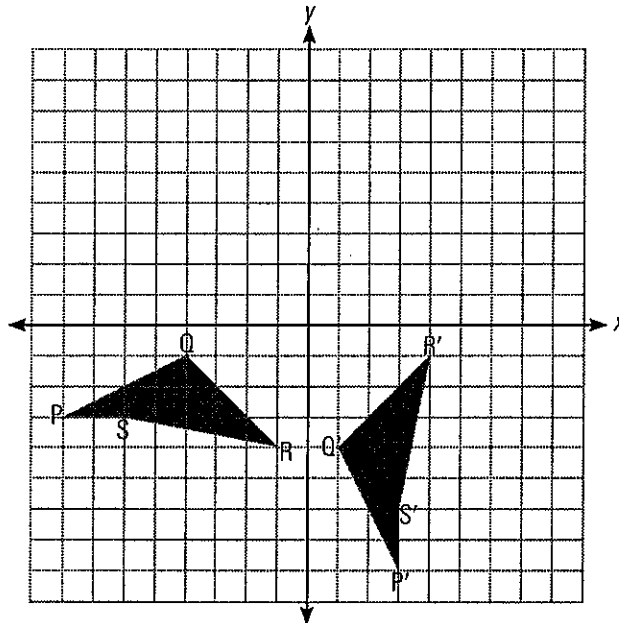

7. The image J''K''L''M''N'' is the result of a translation followed by a reflection across a line. Explain what translation and reflection could have taken place.

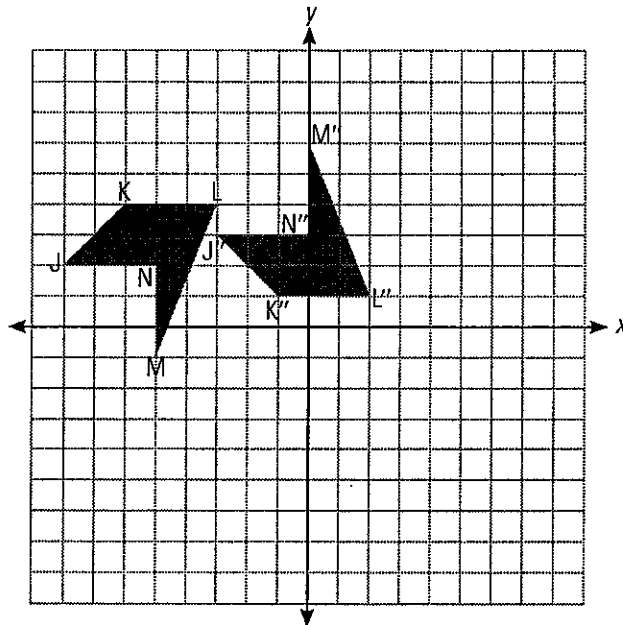

8. Hector says that image $A'B'C'D'$ is the result of a translation 5 units to the right and 4 units down of diagram $ABCD$. Camila disagrees; she says $A'B'C'D'$ was created by a reflection and translation. Who is right? Explain.

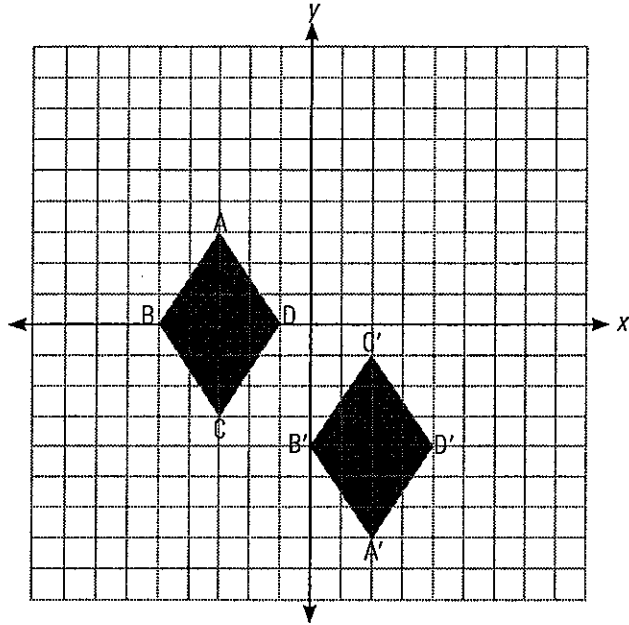

PRACTISE YOUR NEW SKILLS

1. Rotate the isosceles triangle 90° clockwise about the origin and label it $A'B'C'$. Next, reflect $A'B'C'$ over the y -axis and label it $A''B''C''$. State the coordinates.

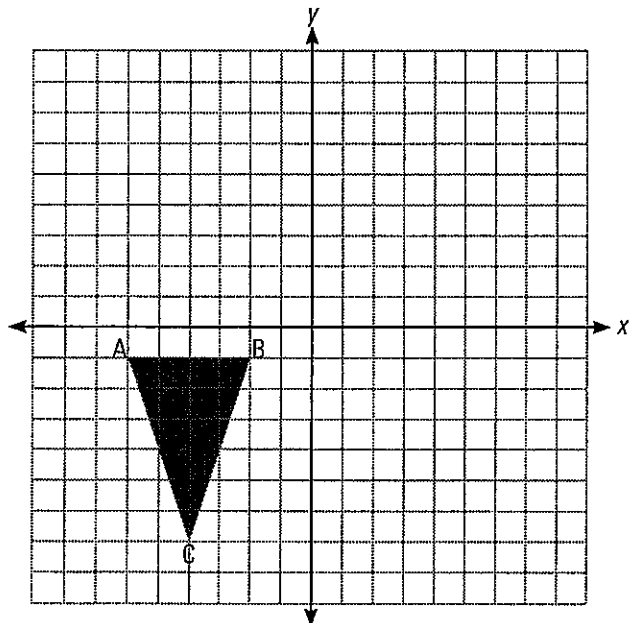

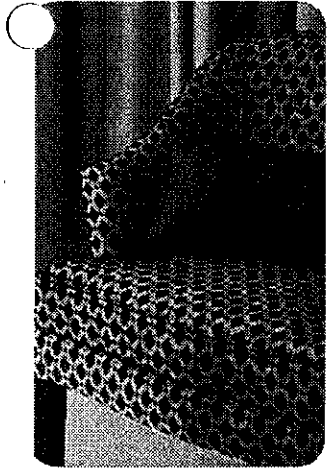

Choosing furniture upholstered with fabric in a bold pattern can enliven and brighten a room.

2. Layla is designing a pattern that will be printed on fabric. She wants to create a repeating pattern. She has drawn one section of the pattern. Rotate the image 90° , 180° , and 270° clockwise about the origin, then translate the entire image 8 units to the right and 4 units up.

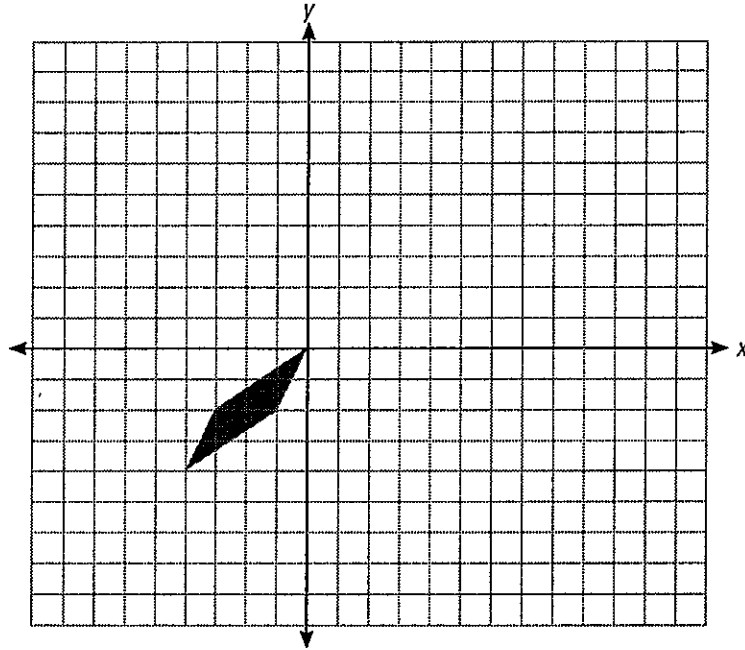

3. Examine the diagrams below. What specific transformations could have taken place to move the shapes from position 1 to position 2? Use the hints provided.

a) The transformation involves a rotation and a translation.

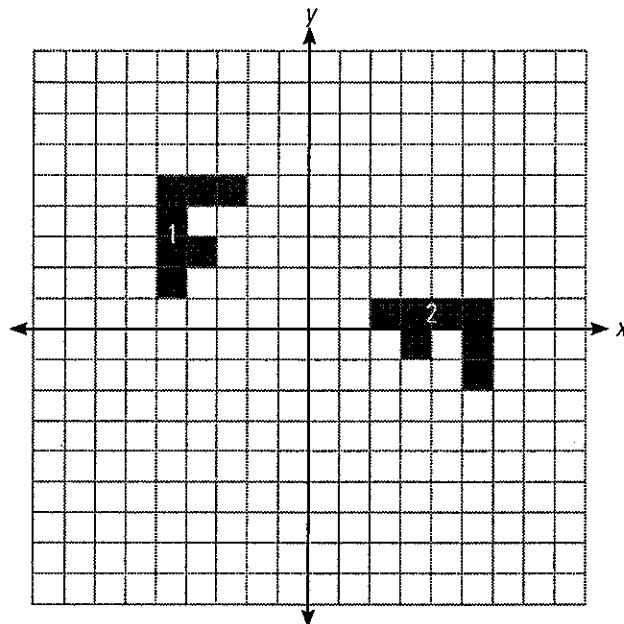

- b) The transformation involves a translation and a reflection.

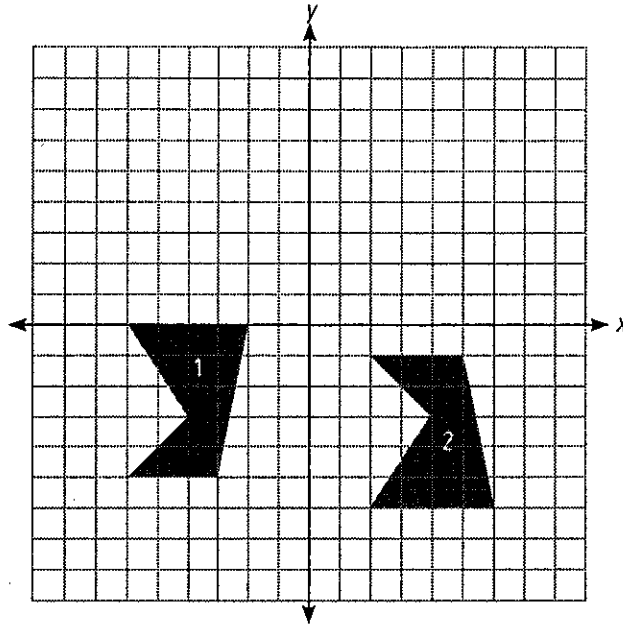

4. a) Translate the following shape 2 units left and 3 down, then reflect it over the y -axis.

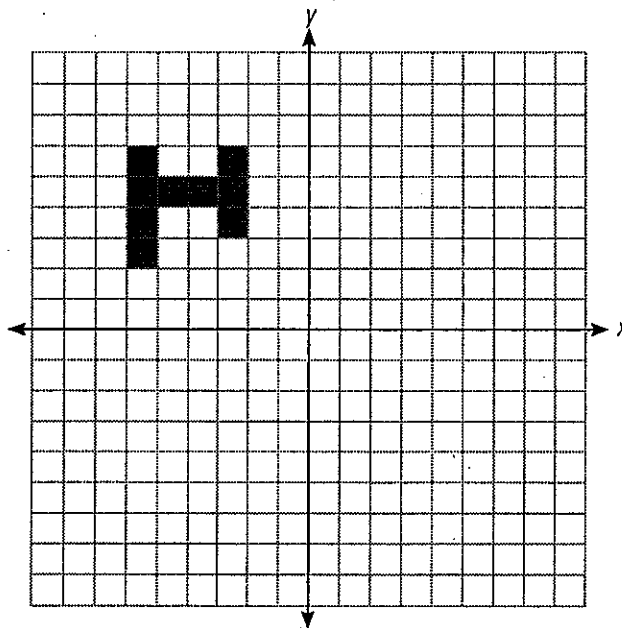

- b) If you reflect the original shape over the y -axis first, what translation will be necessary to create the same image as in a)?

Math 30-3 Transformations Online Resources

1. Transformation Golf

- Google Search "Transformation Golf"
- Select Transformation Golf - Maths Online

2. Math Playground Transformation Workshop

- <http://www.mathplayground.com/TransformationWorkshop/Workshop.html>

3. Math Interactives - Exploring Transformations (Video Interactive)

- <http://www.learnalberta.ca/content/mejhm/index.html> and then follow path Shape & Space - Transformations (Select Video Interactive of West Edmonton Mall). Watch the Video and do the interactive part.

Predicting Snowflakes – Show work here!
(What type of transformation are you using?)

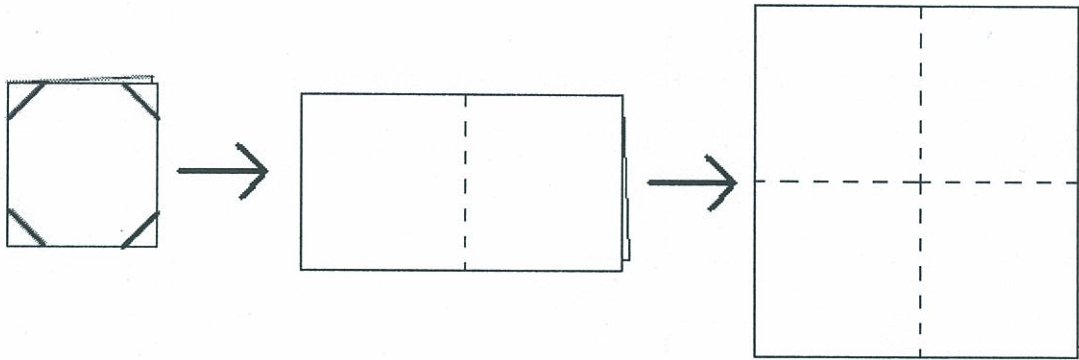

Snowflake prediction

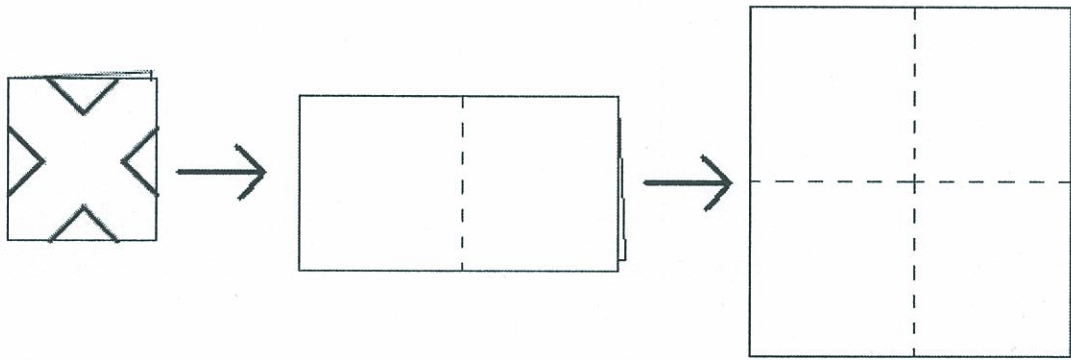

Snowflake prediction

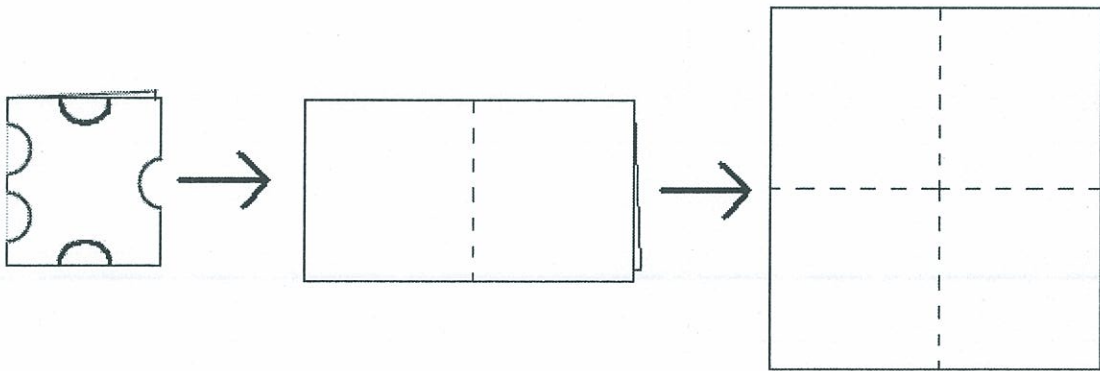

Snowflake prediction

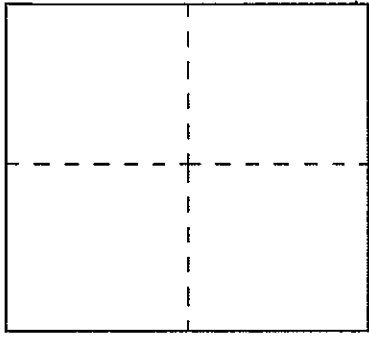

Snowflake prediction

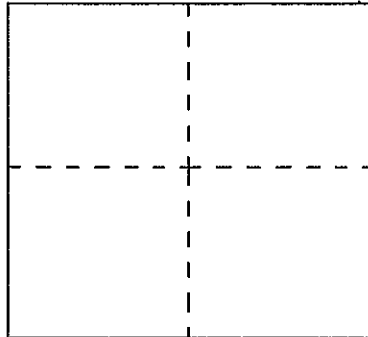

Snowflake prediction

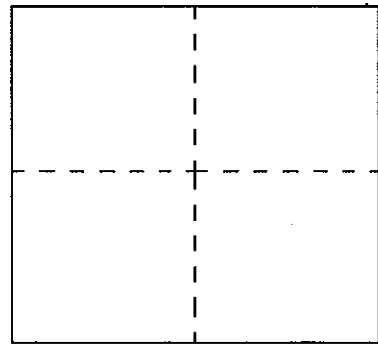

Snowflake prediction

